

Wayne Township  
Single-Family Residential  
Stormwater Management Plan No. 2  
Onlot Detention Basin

A. Criteria for Use:

1. Only 1/4 acre or less of land disturbance on the lot in order to use this plan (12,000 square feet).
2. The remainder of the property is to remain in its original wooded or vegetative condition. If any portion of the lot is a tilled field, it can be converted to grass.
3. Roof area less than 2,000 square feet.
4. Gutters are optional if the site can be graded to direct all roof runoff to basin.
5. Additional impervious area less than 2,000 square feet - driveways, sheds, pools, patios, etc.

B. Construction Criteria:

1. Detention basin to be constructed in accordance with attached drawings.
2. Site to be graded so that all runoff from roof tops and developed areas flow to the detention basin, or runoff should be piped to the detention basin.
3. Detention basin is to be located a minimum of 10 feet from onlot sewage facilities.
4. Property owner and contractor must implement any erosion and sediment controls necessary to comply with Township and State Regulations.

C. Inspection Requirements:

1. Contractor or owner must call for inspection at initial earthmoving, after establishing rock-construction entrance, topsoil stockpile, and erosion controls. Inspection will be scheduled within 72 hours.

2. Contractor or owner must call for inspection when detention basin is constructed; berm is in place; and swales and/or piping are in place to direct runoff to the basin (rough grading). Inspection will be scheduled within 72 hours.
3. Contractor or owner must call for final inspection at completion of earthmoving activities. Inspection will be scheduled within 72 hours. Note that the site must be fully stabilized for a complete final inspection. Driveways must be paved or stone. Lawns must be seeded and/or mulched, or sodded. Erosion controls must be removed (no bare dirt).

Note: If site is not acceptable at any of these inspections, additional site visits may be made - scheduled or unscheduled.

**D. Attachments:**

1. Typical stormwater facilities layout
2. Typical stormwater basin

**E. Additional Reference Material: (not attached)**

1. Erosion and Sediment Pollution Control Program Manual dated March 2012 PADEP document number 363-2134-008 (available at Schuylkill Conservation District Office (570) 622-3742, ext. 5 or online at [www.dep.state.pa.us](http://www.dep.state.pa.us)).
2. Wayne Township Stormwater Management Ordinance.
3. Erosion and Sediment Control Plan Guide for Small Projects in Schuylkill County, dated 3/24/2008, Schuylkill County Conservation District Document. (Available at Schuylkill Conservation District Office (570) 622-3742, ext. 5).

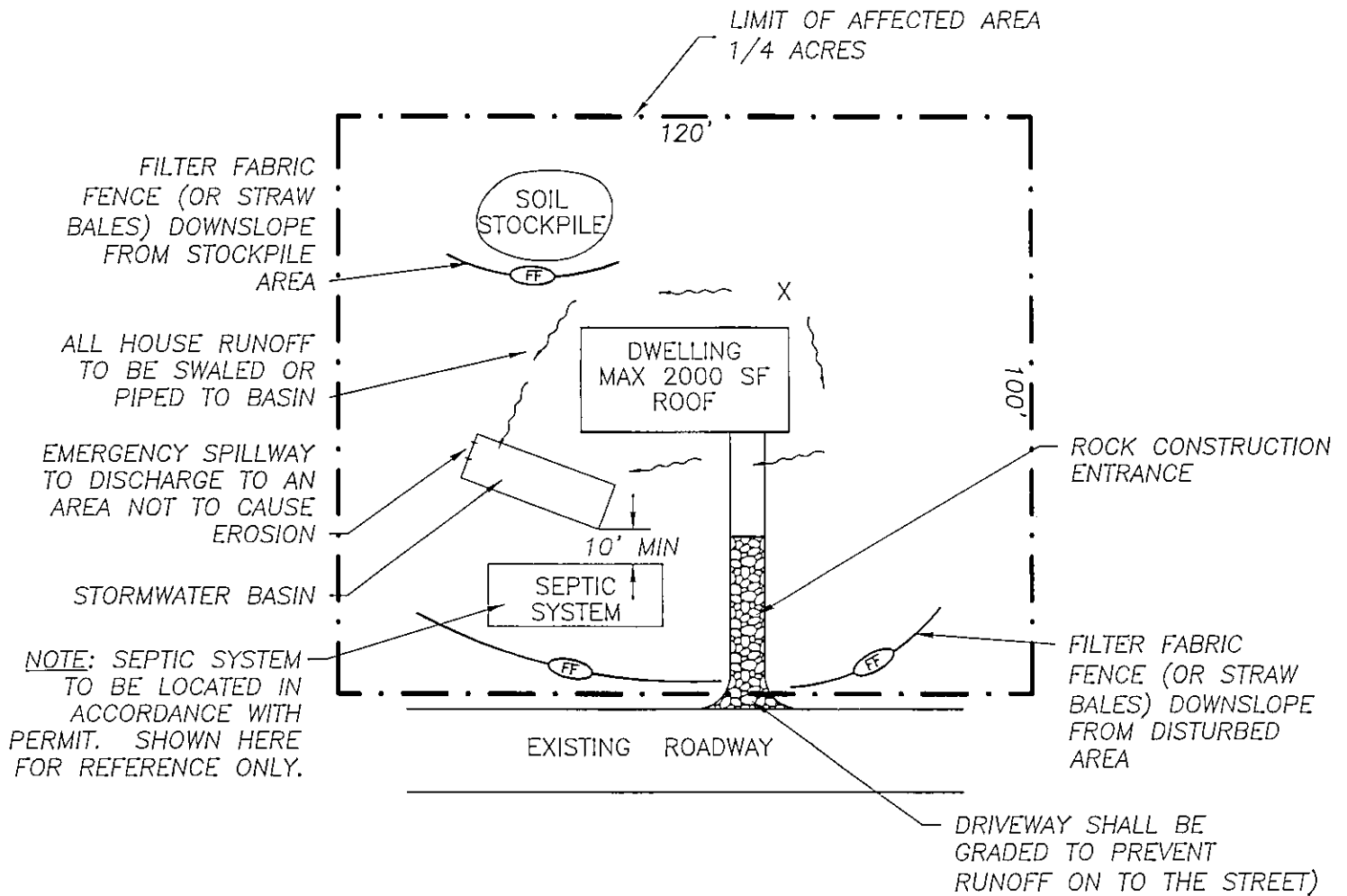

TYPICAL PLAN: ANY REVISIONS BY PROPERTY OWNER TO BE MADE ACCORDING TO THE CONDITIONS OF THE PLAN AND NOTES.

# TYPICAL STORMWATER FACILITIES LAYOUT STORMWATER BASIN

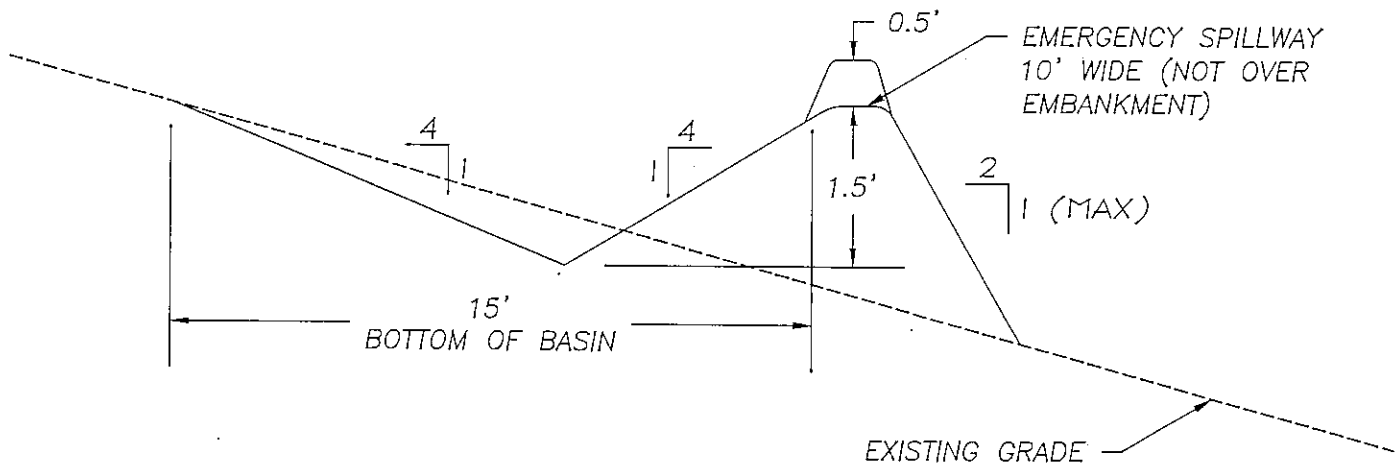

SECTION A-A

10' WIDE EMERGENCY  
SPILLWAY EL 101.50  
(0.5' DEEP IN BERM)  
(NOT OVER EMBANKMENT)

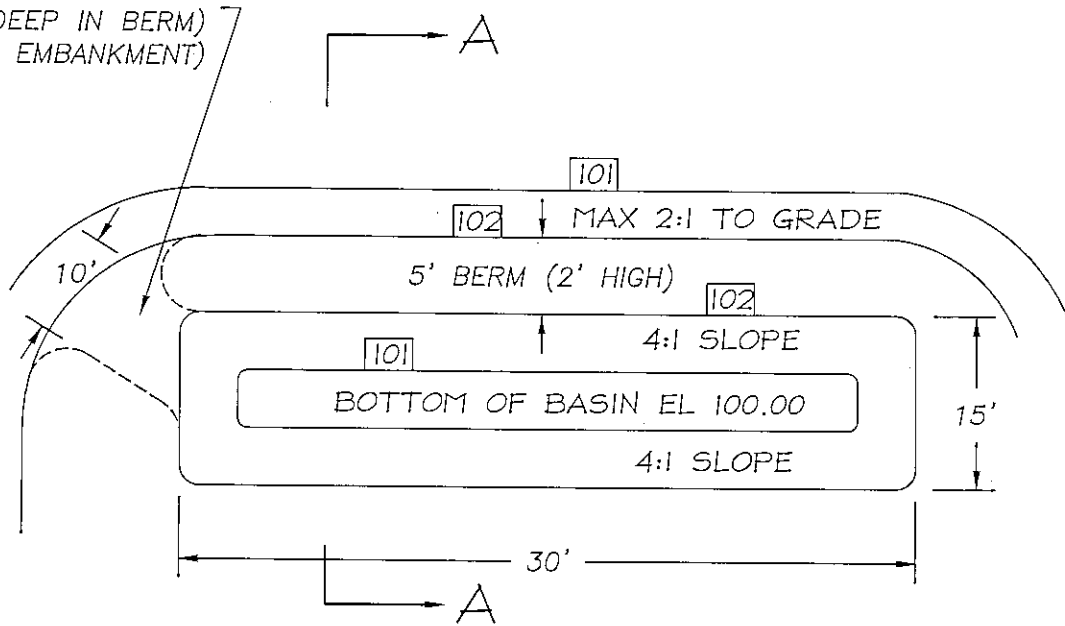

**TYPICAL STORMWATER  
BASIN DETAIL**